



# 5 SERIES 30" AND 36"W. GAS RANGE

Viking 5 Series – VGIC

## COMMERCIAL-TYPE COOKING POWER

- **EXCLUSIVE** – Stainless steel open burners with porcelain/cast iron caps provide restaurant caliber performance
  - All burners are 15,000 BTUs
- **EXCLUSIVE** – VariSimmer™ Setting for all burners
- **EXCLUSIVE** – all burners equipped with SureSpark™ Ignition System for consistent and reliable ignition
  - Automatic re-ignition; surface burners light at any position on the knob and re-light if extinguished, even on lowest setting
- Black Chrome™ knobs shipped standard
- **EXCLUSIVE** – combination of single 30,000 BTU U-shaped burner and infrared broiler with SureSpark ignition system
- Gourmet-Glo™ Infrared Broiler provides intense searing heat for broiling applications
- Large-capacity oven with six rack positions (see specifications for oven interior dimensions)
- Six functions – natural airflow bake, convection bake, infrared broil, convection infrared broil, convection dehydrate, and convection defrost
- All convection modes utilize the ProFlow™ Convection Air Baffle, which is specifically designed to ensure balanced airflow for even heat distribution
- Convection fan switch conveniently located on control panel
- Halogen oven lights for excellent visibility throughout the oven cavity



## EASY OPERATION AND CLEANUP

- Removable porcelain burner bowls provide easy clean-up
- Burner caps are easily removable for quick cleaning
- Heavy-duty, porcelainized, cast-iron removable surface grates provide continuous front-to-rear, left-to-right surface for easy movement of large pots

## MODEL NUMBERS

- VGIC53024B – 30"W. Gas Range; four burners
- VGIC53626B – 36"W. Gas Range; six burners

## ACCESSORIES

- BG8530SS – 8"H. backguard for 30" range
- BG8536SS – 8"H. backguard for 36" range
- HS24530SS – high shelf for 30" range
- HS24536SS – high shelf for 36" range
- P24CSTSS – countertop side trim (2 pieces)
- P30CRTSS – countertop rear trim for 30" range
- P36CRTSS – countertop rear trim for 36" range
- P30CBF4SS – curb base and custom curb base front for 30" range
- P36CBF4SS – curb base and custom curb base front for 36" range
- LPKPDR – LP/Propane Conversion Kit

## COLOR FINISHES

- Stainless Steel (SS) and White (WH)
- Available in 14 exclusive color finishes Alluvial Blue (AB), Arctic Gray (AG), Black Forest Green (BF), Bywater Blue (BW), Cast Black (CS), Cypress Green (CY), Damascus Gray (DG), Frost White (FW) Kalamata Red (KA), Pacific Gray (PG), Reduction Red (RE), Slate Blue (SB), San Marzano Red (SM), Vanilla Cream (VC)



## WARRANTY

- 2-year full – complete product
- 90-day full – cosmetic parts such as glass, painted items and decorative items
- 5-year limited – gas burners



# 5 SERIES 30" AND 36"W. GAS RANGE

Viking 5 Series – VGIC

GAS 30" AND 36"W. OPEN BURNER RANGE		
DESCRIPTION	VGIC53024	VGIC53626
Overall Width	29-7/8" (75.9 cm)	35-7/8" (91.1 cm)
Overall Height	To top of side trim - 35-7/8" (91.1 cm) min. 37" (94.0 cm) max. Legs adjust - 1-1/8" (2.9 cm)	
Overall Depth from Rear*	To end of side panel - 24-5/16" (61.8 cm) To front of door - 25-3/4" (65.4 cm) To end of landing ledge - 28-1/16" (71.2 cm) To end of door handle - 28-11/16" (72.9 cm) *Add 1" to overall depth for ranges with backguards installed against a combustible wall.	
Additions to Base Height	To top of island trim - add 1" (2.5 cm) To top of backguard - add 8" (20.3 cm) To top of high shelf - add 23-1/2" (59.7 cm)	
Gas Requirements	Shipped Natural or LP/Propane, field convert with conversion kit (purchased separately); accepts standard residential 1/2" (1.3 cm) ID gas service line	
Gas Manifold Pressure	Natural 5.0" W.C.P./ Liquid Propane L/P 10.0" W.C.P.	
Electrical Requirements	120VAC/60 Hz; 4 ft. (121.9 cm), 3-wire cord with grounded 3-prong plug attached to unit	
Max Amp Usage	.83 amps	1.5 amps
Surface Burner Rating Natural/LP	15,000 BTU (4.4 kW)/12,500 BTU (3.7 kW)	
Broil Burner Rating Natural/LP	18,000 BTU (5.3 kW)/16,000 BTU (4.7 kW)	
Oven Burner Rating Natural/LP	30,000 BTU (8.8 kW) Nat./LP	
Oven(s) Interior Width	23" (58.4 cm)	29" (73.7 cm)
Oven(s) Interior Height	16-1/8" (40.9 cm)	
Oven(s) Interior Depth	Overall - 18-3/4" (47.6 cm)	
Oven(s) Volume		
Overall AHAM	4.0 cu. ft. 3.7 cu. ft.	5.1 cu. ft. 4.6 cu. ft.
Approximate Shipping Weight	410 lbs. (184.5 kg)	500 lbs. (225 kg)

Please do not prepare installation from brochure data only. See installation instructions for important clearance/installation information.  
\*\*The AHAM Standard for measuring oven capacity subtracts the door plug and convection baffle dimension from the total oven volume.

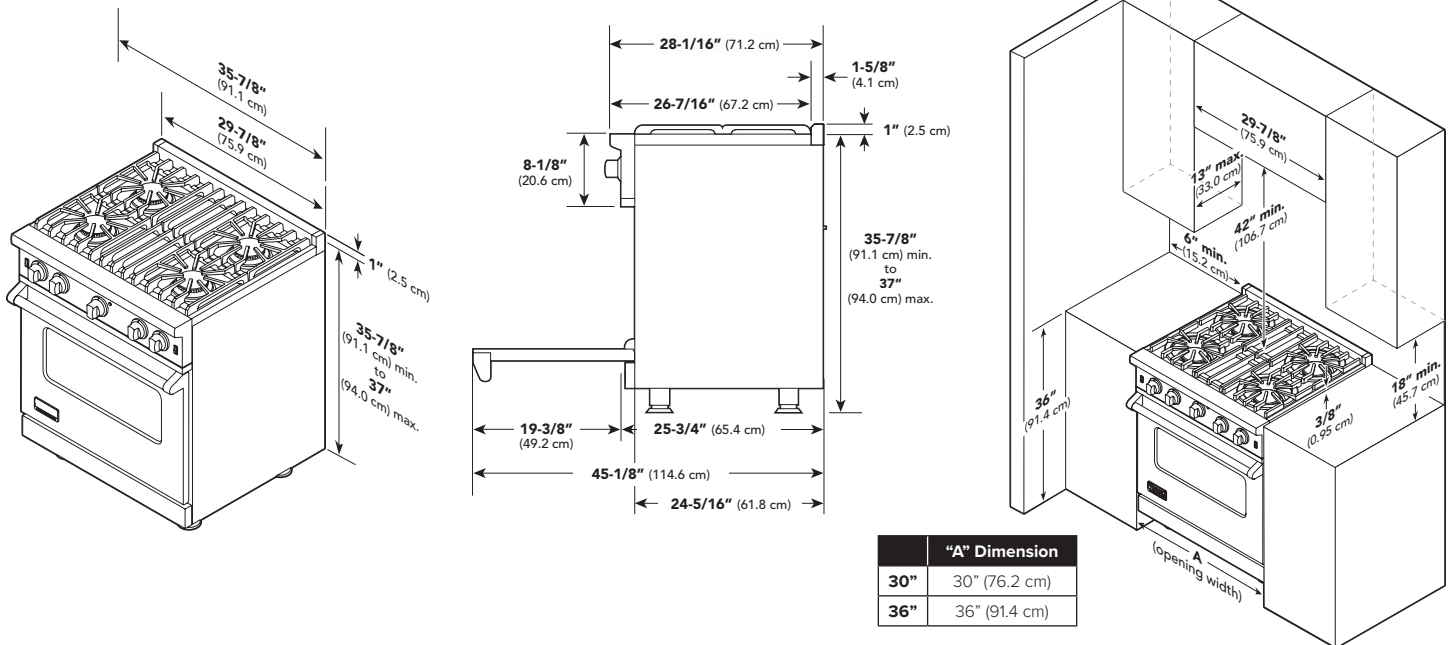

VIKING RANGE, LLC 111 FRONT STREET GREENWOOD, MISSISSIPPI 38930 USA

For detailed product information, model numbers, or to request a quote call 1-888-845-4641 or visit [vikingrange.com](http://vikingrange.com)  
© 2020 Viking Range, LLC All rights reserved. Specifications subject to change without notice.